

WDS Autogate

T. 01902 565850

F. 01902 565851

E. Technical@autogate.co.uk

www.autogate.co.uk

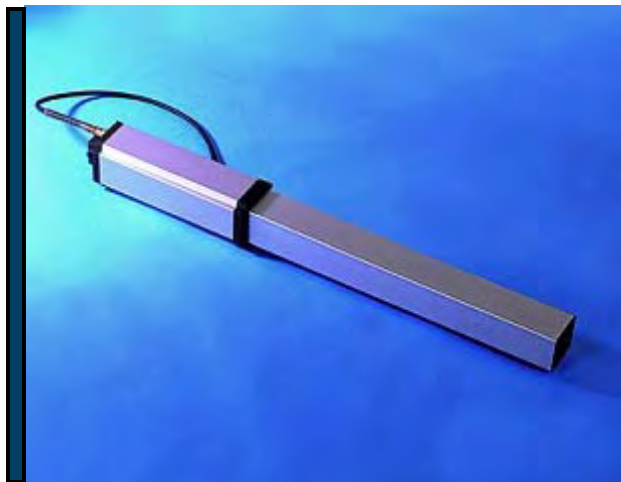

Swift

Installation Manual

CE

INTRODUCTION

The **Swift 270/385** motor is a hydraulic operator which is suitable for the automation of metal and wooden swing gates. The motors can be mounted in two ways to obtain an inward or outward opening.

INSTALLATION REQUIREMENTS

PLEASE READ THE FOLLOWING INFORMATION CAREFULLY AND ENSURE THAT ALL REQUIREMENTS ARE OBTAINABLE BEFORE INSTALLATION.

- Gates must not exceed the maximum length as stated in Technical Details table.
- All **Swift** motors require certain measurements for fitting brackets (*Fig. 4*). These must be followed as incorrect geometry may result in the incorrect operation.
- Adequate side room is needed for each motor to operate.
- Physical stops are needed to cease the gates' operation. A centre stop is a compulsory requirement as are 90° fully open stops.
- Brackets that are supplied may not be suited to the measurement you require as all applications vary. Brackets may need fabricating/altering.
- A 240vac power supply is required to one side of the gate (where the control unit is to be housed) fused at 10amps - complete with an RCD protection device.
- If a hardwired intercom system or other controls from the house are to be installed, a communications cable will be needed from the house to control unit.
- A duct between the posts is required to carry cables to second motor and to connect safety photocells.
- The services of a qualified electrician will be required to carry out electrical connections and power supplies/communication cable routing.

TECHNICAL DETAILS

	SWIFT 270
Power Supply	230vac - 50/60Hz
Current absorption	1.2A
Capacitor	10MF
Thermal protection cut-in	120°
Operations per hour	70
Pull/thrust force	500kg
Electric motor speed	1400 R.P.M
Operator rod speed	13mm/sec
Operator rod stroke	270mm
Maximum rod stroke time	20.5sec
Maximum gate length	1800mm
Maximum gate weight	400kg
Oil	AGIP A 15 - MOBIL AEREO HFE

MOTOR CONTENTS - Fig. 1

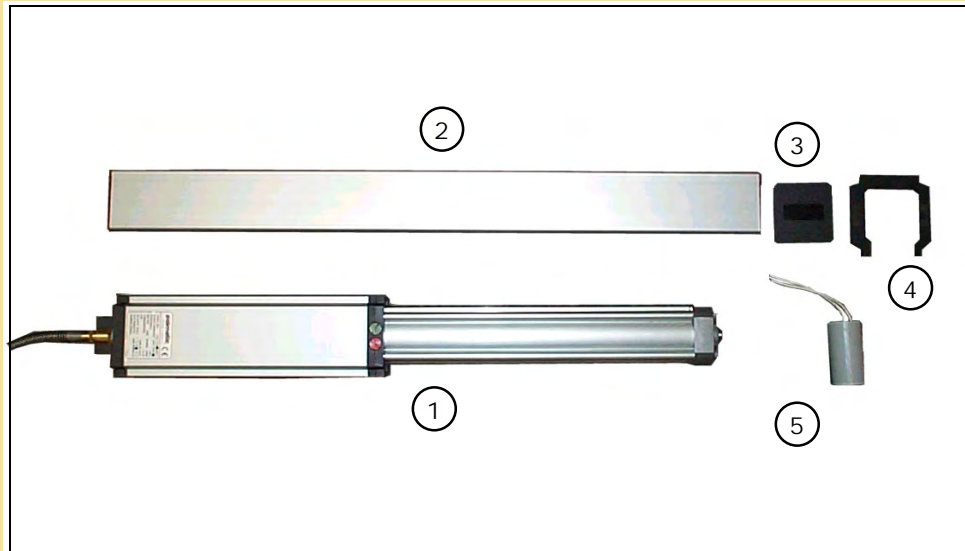

- ① SWIFT 270/385 MOTOR
- ② PISTON COVER
- ③ COVER CAP
- ④ PRESSURE SCREW COVER
- ⑤ MOTOR CAPACITOR

PLEASE NOTE, If any of these items are missing from your consignment, please contact your supplier before commencing with installation.

BRACKET CONTENTS - Fig. 2

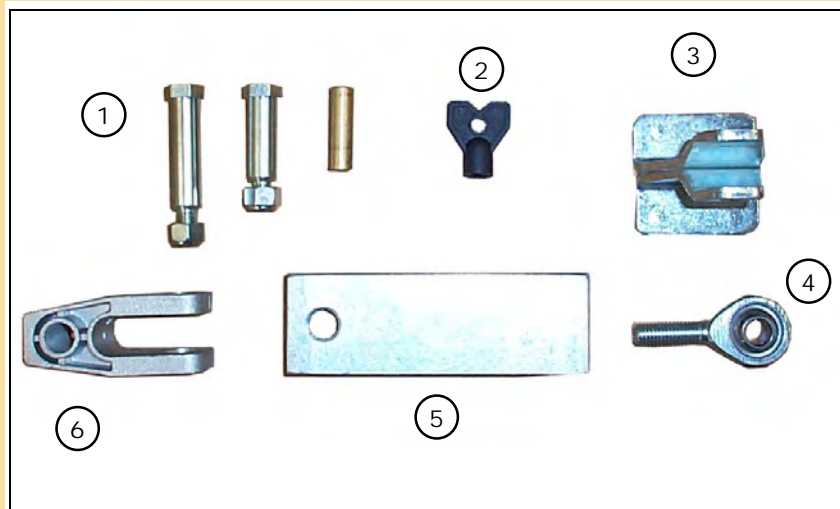

- ① HOLDING PINS FOR BRACKETS
- ② MANUAL RELEASE KEY
- ③ BRACKET C
- ④ FRONT BEARING
- ⑤ BRACKET A
- ⑥ BRACKET B

PLEASE NOTE, If any of these items are missing from your consignment, please contact your supplier before commencing with installation.

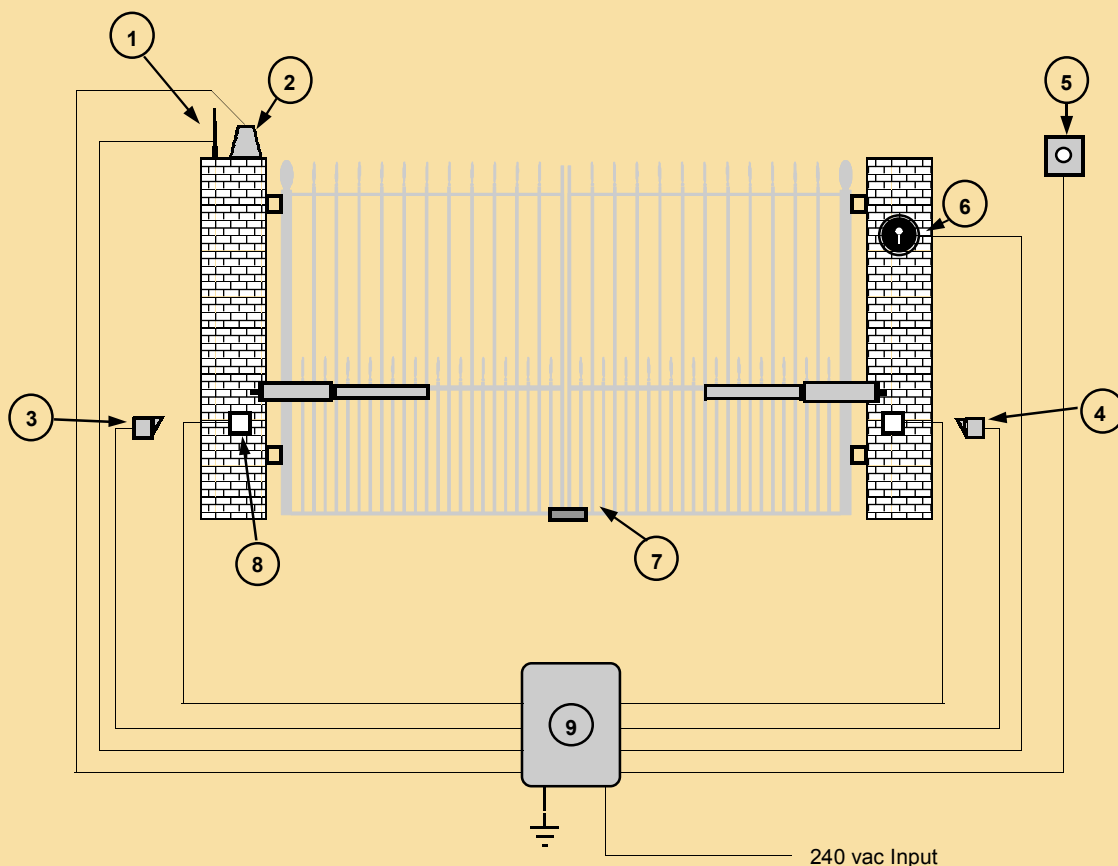

1 - Aerial - Pre wired. Gives added range to your remote transmitter (approx. 40m). Recommended fitting location is a high point with a clear line of sight. Usually at the top of you post.

2 - Warning light (optional) - 3 x 1.5mm wire. Emits a flashing light to warn others that an automatic gate is in operation. Recommended fitting location is a high point with a clear line of sight. Usually at the top of post.

3 - Safety photocell (receiving) - 4 x 0.5mm wire & 4 - Safety photocell (emitting) - 2 x 0.5mm wire. Photocells are primarily used as a safety feature but can also be used for automatic entry/exit. We recommend that the photocells are always installed to give maximum safety to vehicles and pedestrians. Photocells pass an infra-red beam between themselves. When the gates are closing, and the beam is broken (by a vehicle or pedestrian) the gates will instantly stop and re-open. Recommended fitting location is between your gate pillars on the outside (opposite to the movement of the gate, therefore the gate will not break their beam during the cycle) at a height of approximately 500mm from floor level.

5 - Internal push button station/access facility (optional) - 2 x 0.5mm wire. Creates a normally open switch to release the gate from inside the property or at the gate.

6 - Key switch - 2 x 0.5mm wire. Used to access the gates with a conventional key. Recommended fitting location is on the gate pillar, inside or out, depending on the required function.

7 - Centre stop. This is essential to the overall operation of the gates and, if not existing, can be purchased from your supplier if required. Alternatively any suitable centre stop can be used.

8 - Junction boxes for motors - 4 x 1.5mm wire. Used to junction motor cable before routing back to PM8000 control unit.

9 - PM8000 control unit. Central control unit where all connections are made. Please refer to separate instruction manual for wiring diagrams and operational functions. Recommended fitting location is local to gates behind gate post or fixed to the back of adjacent wall.

Please note, all fitting locations are recommendations only.

SWIFT 270/385 FITTING - Fig. 4

Gate opening inwards (towards property)

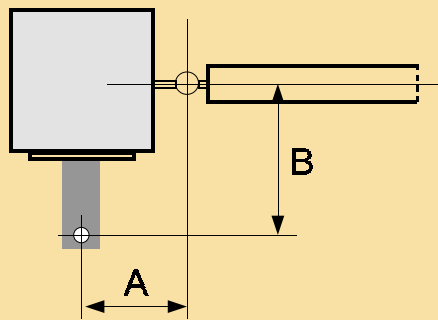

Gate opening outwards (against property)

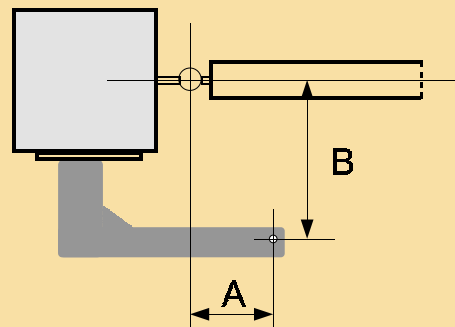

Swift - All measurements in mm.

SWIFT 270	A	B
90° Opening	145	145
120° Opening	160	120

SWIFT 385	A	B
90° Opening	195	195

SWIFT 270 FITTING - Fig. 5

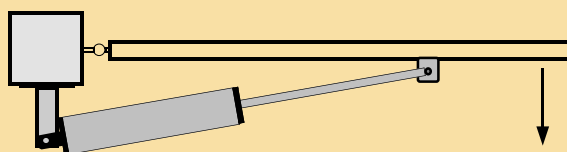

Gate opening inwards (towards property)

When motor is fitted, the arm should be near to full extension (see installation instructions). When opening the arm retracts and pulls the gate open (direction of arrow). When closing the arm extends and pushes the gate to the closed position.

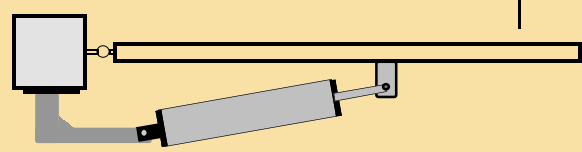

Gate opening outwards (against property)

When motor is fitted, the arm should be near to full retraction (see installation instructions). When opening the arm extends and pushes the gate open (direction of arrow). When closing the arm retracts and pulls the gate to the closed position.

SWIFT 270/385 INSTALLATION - Installation recommendations

Motors should be fitted as near to middle of the gate as possible. Preferably on a mid rail.

For metal gates/posts, we recommend welding brackets in position.

For wooden gates/posts, we recommend that the brackets are welded to plates to distribute the pressure evenly and through bolts are used with plates at the opposing side. This will help to prevent the brackets pulling into the wood during operation.

SWIFT 270/385 INSTALLATION - Opening inwards

- Check that you have all listed components in *Fig. 1 & 2*.
- Check **Installation requirements** on page 1 and ensure that application satisfies all points.
- Before commencing, ensure gates are in closed position against centre stop.
- Calculate the correct location/size of bracket **A** using *Fig. 4*. and fix to gate post.
- Attach the back junction of the motor to bracket **A** using bracket **B** and appropriate holding bolts, securing with nuts (*Fig. 6*).
- Take the manual release key and insert it into the triangular lock valve situated on the underside of the motor. Rotate anti-clockwise. This allows the piston to be controlled manually (this is also the procedure during power cut or emergency situation).
- Extend the piston to its full length (you may find it useful to fit the front bearing and pull with a screwdriver). Once the piston is at its full travel, push back approx. 50 mm.
- Screw the front bearing to the motor piston ensuring that when fitted, the nut provided is tightened to hold the position tightly.
- Attach bracket **C** to the front bearing using the supplied holding pin and circlips (*Fig. 7*).
- Offer bracket **C** to the gate (ensuring that the gate is in the closed position). This is the correct location for bracket **C** to be fixed.
- Fix bracket **C** to gate ensuring that once fixed, the motor is on a level horizontal line.
- Once the brackets have been fitted and the actuator is supported adequately, slowly open and close the gate manually to ensure smooth travel through the 90° opening.
- Once satisfied with the fitting, re-engage the motors by reversing the manual release procedure.
- Slide cover over the pressure adjustment screws followed by piston cover and secure with supplied screws.
- Connect the motor wires to your control unit (these may need to be junctioned in adaptable boxes). Please refer to your PM8000 control unit instruction for all wiring directions/information.

Motor cable, **Blue** = common, **Brown & Black** = direction (open & close), **Yellow/Green** = earth.

SWIFT 270/385 INSTALLATION - Opening outwards

- Check that you have all listed components in *Fig. 1 & 2*.
- Check **Installation requirements** on page 1 and ensure that application satisfies all points.
- Before commencing, ensure gates are in 90° open position against stops.
- Calculate the correct location/size of bracket **A** using *Fig. 4*. and fix to gate post.
- Attach the back junction of the motor to bracket **A** using bracket **B** and appropriate holding bolts, securing with nuts (*Fig. 6*).
- Take the manual release key and insert it into the triangular lock valve situated on the underside of the motor. Rotate anti-clockwise. This allows the piston to be controlled manually (this is also the procedure during power cut or emergency situation).
- Extend the piston to its full length (you may find it useful to fit the front bearing and pull with a screwdriver). Once the piston is at its full travel, push back approx. 50 mm.
- Screw the front bearing to the motor piston ensuring that when fitted, the nut provided is tightened to hold the position tightly.
- Attach bracket **C** to the front bearing using the supplied holding pin and circlips (*Fig. 7*).
- Offer the arm up to gate and mark the point where bracket **C** is to be fixed.
- Close gate against centre stop.
- Retract arm until the end of the arm matches the bracket **C** mark point. This point should be easily reached and the piston should not be fully retracted. This action will simulate the motor's movement in operation and should be checked before fixing the bracket to ensure the gate will open and close fully. If the arm does retract fully and the point isn't yet reached, the geometry of bracket **A** will need alteration.
- Once bracket location is confirmed, fix bracket **C** to the gate ensuring the motor is on a level horizontal line.
- Once the brackets have been fitted and the actuator is supported adequately, slowly open and close the gate manually to ensure smooth travel through the 90° opening.
- Once satisfied with the fitting, re-engage the motors by reversing the manual release procedure.
- Slide cover over the pressure adjustment screws followed by piston cover and secure with supplied screws.
- Connect the motor wires to your control unit (these may need to be junctioned in adaptable boxes). Please refer to your PM8000 control unit instruction for all wiring directions/information.

Motor cable, **Blue** = common, **Brown & Black** = direction (open & close), **Yellow/Green** = earth.

Please note - All of the above is our recommendation only

SWIFT 270/385 INSTALLATION

Fig. 6 - Bracket A & B assembly



Fig. 7 - Bracket C & front bearing assembly

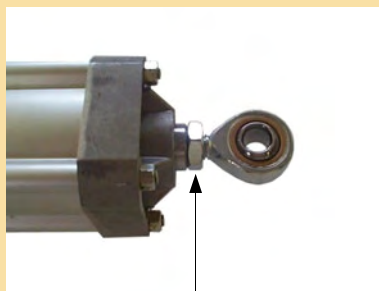

Please ensure nut is tightened to secure front bearing position

SWIFT 270/385 INSTALLATION - *Electrical connection*

WE ONLY SUGGEST CARRYING OUT ELECTRICAL CONNECTION USING THE SERVICES OF A QUALIFIED ELECTRICIAN.

For full wiring instruction of motor and accessories, please refer to the PM8000 control unit manual.

SWIFT 270/385 INSTALLATION - System test

Upon completion of mechanical installation and electrical connection we recommend that the system is tested. Please follow the test procedure below,

- Switch power off.
- Manually release both motors.
- Open both gates to a 45° angle.
- Re-engage motors (reverse manual release procedure).
- Move pressure screw cover to one side to reveal adjustment screws. These adjust the pressure of the opening/closing of the piston. Red= close, Green=open, Clockwise = increase pressure, Anti-clockwise = decrease pressure.
- Set pressure for opening and closing to just above minimum.
- Apply power.
- Give signal from access unit i.e. transmitter, key switch.

Note, At the initial signal the motors should always move in the opening direction, if this is not the case for one or both of the motors, the directional wires (brown & black) of each motor must be reversed.

- Slowly adjust pressure to suit. **Note,** when adjusting pressure please be aware that these are very powerful motors and adjustment should be made in moderation until desired movement is obtained. We recommend that motors should be set to low pressure so that the gates will stop when minimal force is applied to prevent damage to cars or pedestrians, however weather conditions should also be taken into consideration.
- Once pressure is set, run motors for a number of operations to evaluate whether any operational timer adjustments are needed. These timers are found in PM8000 control unit and include, **run timer** (amount of time motors are running for), **delay timer** (allowing a delay between first and second motor) and **pause timer** (amount of time motors remain open before closing). All timer adjustments are detailed in control unit instruction.

Please note, system is set up for automatic closure. If this is not required, please refer to control unit instruction to alter the system operation.

When desired adjustments have been made, recover pressure adjustment screws.

Fig. 8

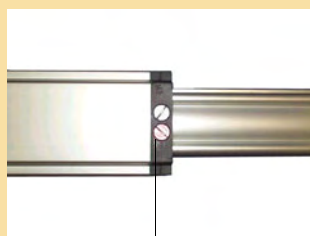

PRESSURE ADJUSTMENT SCREWS
Green = open, Red = close

Fig. 9

Please note,

A breather screw is installed before despatch as a measure to prevent oil spillage in transit. This screw must be removed before automatic operation and is situated as adjacent diagram. Slight oil spillage may occur which is normal.





SWIFT 270/385 MAINTENANCE

Swift 270 motor is generally maintenance free.
On completion of installation it is recommended to lubricate all pivot points and the motor piston with industrial grease to ensure friction-free movement.

ADDITIONAL ACCESSORIES - *Security, safety, access control*

WDS supply a range of additional extras that can enhance your system. These include additional,

- Security and visitor identification.
- Safety equipment.
- Advanced access control equipment.

All products and full descriptions can be found on page 9 of **WDS** company brochure.



Wolverhampton Door Services Ltd

Tel: +44 (0) 1902 565850 • Fax: +44 (0) 1902 565851

Email: technical@autogate.co.uk

www.autogate.co.uk